

JAKA <http://kair.us/>

weller_driver_v1
9.5.2016 21:56:07
Sheet: 1/3

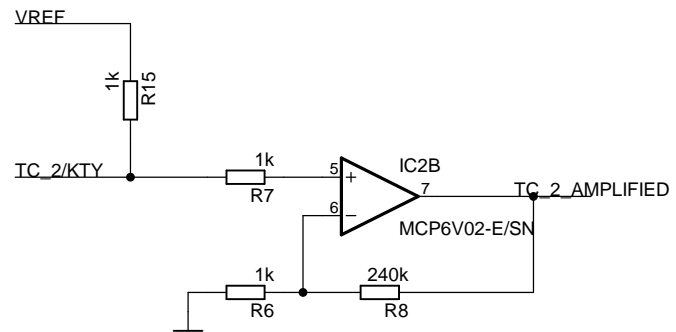
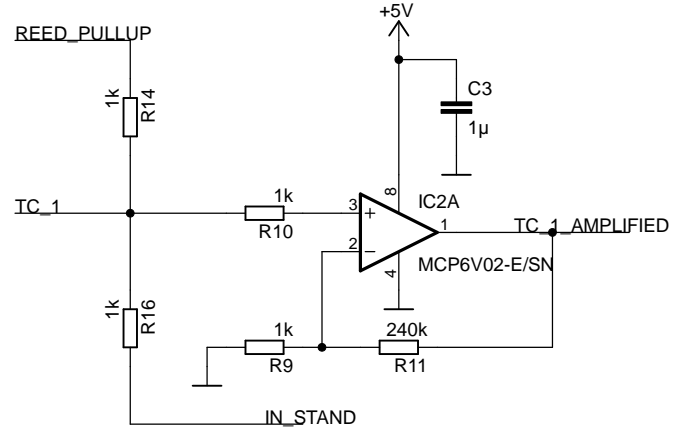
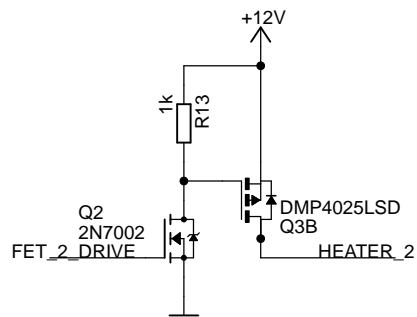
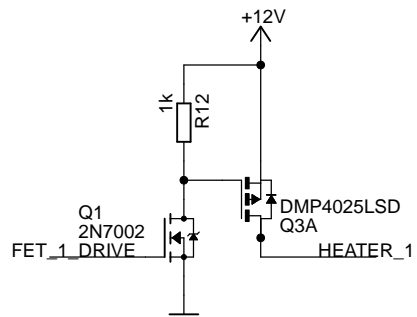

<http://kair.us/>

weller\_driver\_v1

9.5.2016 21:56:07

Sheet: 2/3

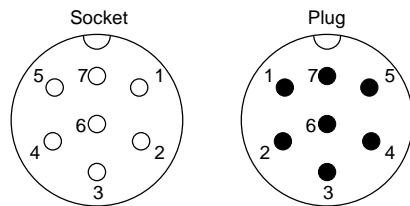

PIN	WMRP	WMRT
1	GND	GND
2	N/C	HEATER 2 (LEFT)
3	N/C	N/C
4	KTY 82	TC 2 / KTY 82
5	POTENTIAL	POTENTIAL
6	TC1 / REED	TC1 / REED
7	HEATER	HEATER 1 (RIGHT)

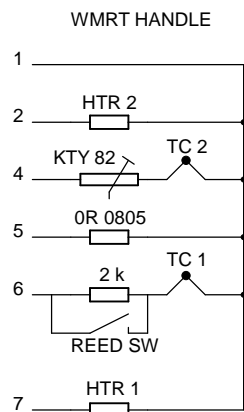
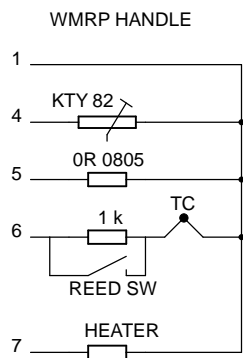

#### NOTES

KTY82 is a silicon temperature sensor made by NXP. (KTY82/110). It is inside the handle and used to measure thermocouple cold junction temperature.  
 Reed switch is activated by a magnet in stand. The resistor in parallel with reed switch is used to detect the tool. This however prevents detecting tool type when in stand.  
 Pin 5 is for decreasing potential difference between iron and the parts to be soldered. Should be connected to mains ground or workbench ESD ground through 1 Mohm.  
 Depending on the power supply type used to power this Weller controller, the ESD protection might or might not work.  
 Connector pinouts above are seen from contact side, not solder side.